

Interface & Connection Schedule				
NO.	Use interface	Flange size	Standard flange	Effective hole
a	Feeding Flange	DN200	JIS 10K	150
b1	Closed filtration flange1	DN100	JIS 10K	80
b2	Closed filtration flange2	DN100	JIS 10K	80
b3	Closed filtration flange3	DN100	JIS 10K	80
b4	Closed filtration flange4	DN100	JIS 10K	80
c1	Squeezing line flange1	DN50	JIS 10K	50
c1	Squeezing line flange2	DN50	JIS 10K	50

parameter list of equipment			
motor power of plate shifting kw	1.1	plate specification mm	1500×1500×75 1500×1500×85
working pressure of cylinder MPa	25	cake thickness mm	35
motor power of hydraulic station kw	11.0	filtration pressure MPa	0.8
Feed temperature C	60	squeezing pressure	1.0
filtration area m ²	285	chamber number	82
chamber Volume m ³	5.0	total length mm	11550
anchor hole mm	8800	total weight kg	22880

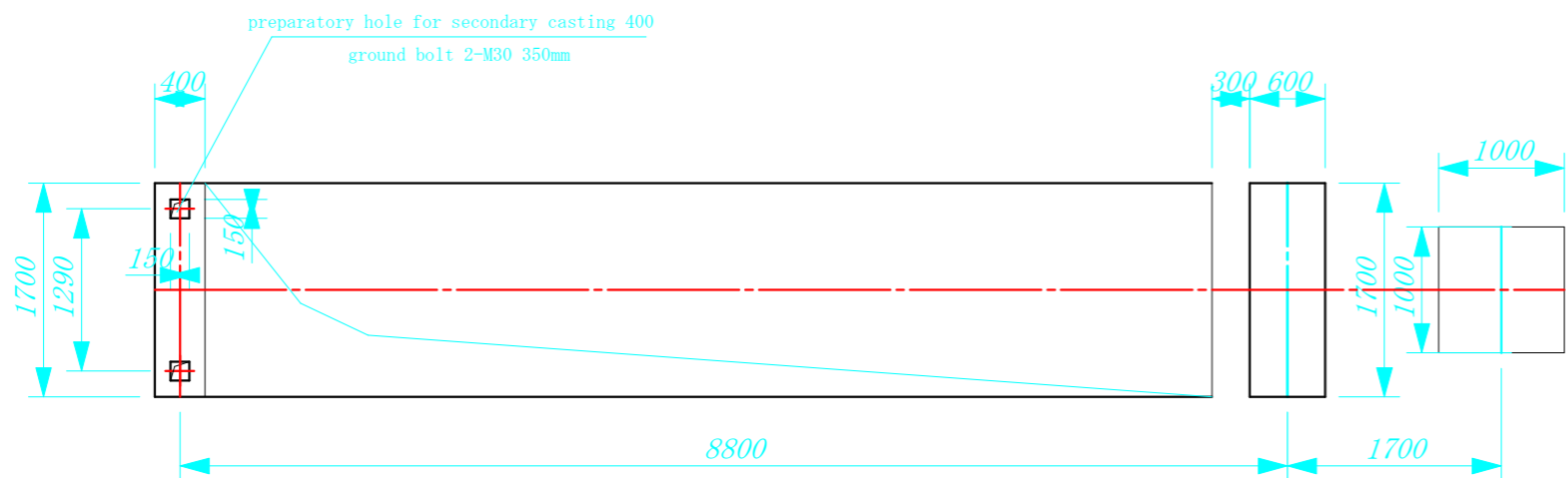
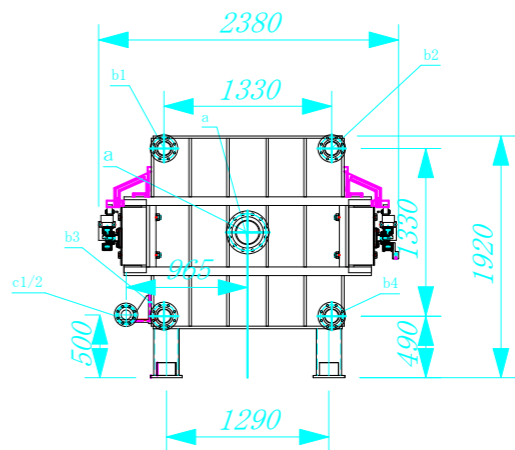
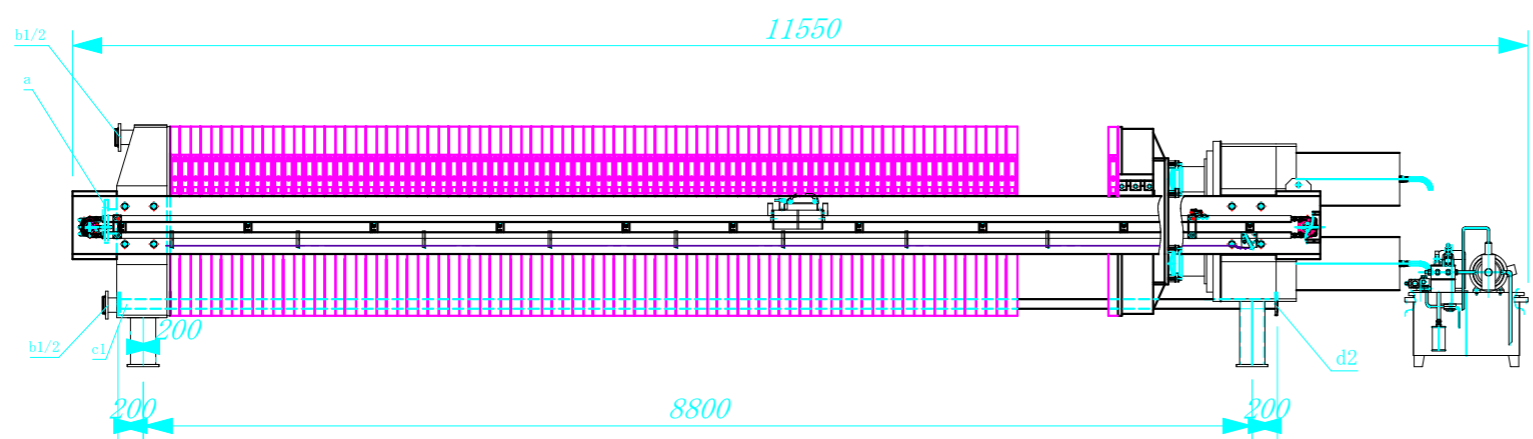

		Auto Filter Press		Jing Jin Group	
				XAZG285/1500-UB	
Dong		Foundation Drawing		1:40	
				2012.02.07	